

OCULUS

Pentacam®
Pentacam® HR

The Gold Standard in
Anterior Segment Tomography



We focus on progress

Providing the Best Care to Your Patients

> Sight is the most important sense.

Loss or impairment of sight is something your patients would rather not even imagine.

> Fast, non-contact measurements will find favour with your patients.

Establish good doctor-patient relationships by showing your patients the intuitive Pentacam® displays and discussing treatment options with them.

> Your staff will appreciate the ease of use and seamless connectivity to the EMR System.

> The OCULUS Pentacam® wins patient trust.



Establish the basis for long-term relationships with your patients.



Glaucoma screening

I went to my eye doctor to get contact lenses. A quick Pentacam® exam revealed very small anterior chamber angles and showed that I was a glaucoma risk patient. According to my doctor this early detection was crucial in managing the condition and preserving my eyesight!

Cataract surgery

Following a Pentacam® examination my doctor used the Pentacam® images on his iPad® and showed me my cloudy crystalline lens. I was surprised that I could see anything at all! My doctor used the Pentacam® information to select and recommend a premium IOL. I am delighted with the result of my cataract surgery and recommend my doctor to all my friends.

Refractive surgery

I was tired of wearing eye glasses and went to a refractive surgeon to explore the options for refractive surgery. A Pentacam® exam confirmed that I was a good candidate for LASIK. My doctor used my Pentacam® images and explained the surgery in detail. I was happy with the competent consultation and careful evaluation prior to surgery.



Pentacam®

The Affordable Model

The Pentacam® measures the cornea from limbus to limbus. It measures up to 25,000 true elevation points. During the rotating scan that takes max. 2 seconds, up to 50 Scheimpflug images of the anterior eye segment are captured with outstanding precision. Based on these images the Pentacam® provides topographic data on elevation and curvature of the entire anterior and posterior corneal surfaces. The corneal thickness (pachymetry) is measured and presented graphically over its entire surface. A topography based keratoconus detection and quantification are performed. The anterior chamber depth, chamber volume (size) and the chamber angles are automatically calculated and presented for glaucoma screening. The illumination of the eye using blue LED light makes corneal and lens opacities (cataract) visible. The anterior chamber can be visualised and displayed with the virtual tomography model.

After measurements have been taken and the quality specifications of the scan have been checked by the user the Pentacam® can generate an Indices Report. This Indices Report summarises the abnormalities found during the scan to direct doctor's attention to the areas of concern. This report is based on published clinical studies and articles that define abnormalities.

The standard model is affordable and is suitable for pre-exam lanes, satellite offices and for quick screenings.



Now with a new iris camera lens system for automatic HWTW measurement.

Basic Software:

- ✳ Indices Report to detect abnormalities in the anterior eye segment
 - for glaucoma screening
 - for refractive screening
- General Overview Display
- 4 Maps Refractive
- Qualitative assessment of the cornea
 - Topography and elevation maps of the anterior and posterior corneal surface
 - Overall pachymetry, absolute and relative
- Iris camera and automatic HWTW
- Topography based keratoconus detection and classification
- 3D anterior chamber analysis
- Comparison and differential analysis of 2 exams
- Comparison and superimposition of Scheimpflug images
- Overview of all captured Scheimpflug images
- Anterior segment tomography

Pentacam® HR

The Professional Model

The Pentacam® HR is our high resolution model, measuring up to 138,000 true elevation points. It is equipped with a high resolution CCD chip and optimized optics.

While performing a rotating scan the Pentacam® HR captures up to 100 high-resolution Scheimpflug images to provide a detailed analysis of the cornea. IOLs and pIOLs, corneal rings, corneal injuries and corneal opacities such as in Fuchs dystrophy are thus brought into view in brilliant detail. The crystalline lens is displayed from anterior to posterior capsule, even with opacities present.

The Pentacam® HR is optionally available with a unique 3D pIOL simulation software including aging prediction.



Now with a new iris camera lens system for automatic HWTW measurement.

This is What Makes the HR Special:

- High resolution CCD camera and high end optical design to generate brilliant Scheimpflug images to display
 - corneal opacities, corneal implants and rings
 - IOLs and pIOLs in terms of position and orientation
 - PCO (posterior capsular opacification)
- ✳ Special scan mode to display pIOLs
- ✳ Precise measurement of the cornea with up to 100 Scheimpflug images
 - Movable fixation target
- ✳ 3D pIOL simulation software including aging prediction

✳ These functions are unique and are only available with the OCULUS Pentacam®

Data Network

The Pentacam® comes with a free patient data management software that ensures increased efficiency and networking capabilities.

EMR Compatibility

The Pentacam® software is compatible with many commercially available EMR systems. This allows a quick and paperless transfer of examination results and reports to all workstations.

DICOM Compatibility (Optional)

The Pentacam® software is fully DICOM compatible. The Pentacam® software receives information from the DICOM Modality Work List (MWL) from the Hospital Information System (HIS) and transmits the results to the Picture Archiving and Communication System (PACS) for storage and further evaluation.

Software Licenses on a Floating License Key

The Pentacam® results can be displayed as static pages on workstations in a network. To have full functionality of the Pentacam® software and to be able to interactively work with it, additional analysing software options may be required.

The new OCULUS Floating License Key is designed to work in a local network and is plugged into the central server. It is equipped with the basic software and provides parallel access to the Pentacam® basic software results from every workstation. The Floating License Key can support multiple instruments such as Pentacam®, Keratograph 5M and other OCULUS devices simultaneously. In addition to the basic software other optional software modules can be purchased and added to the floating license key. This allows viewing the additional software features on parallel workstations. For example, the Holladay Report can be used on 2 and the Belin/Ambrósio Enhanced Ectasia software on three workstations.

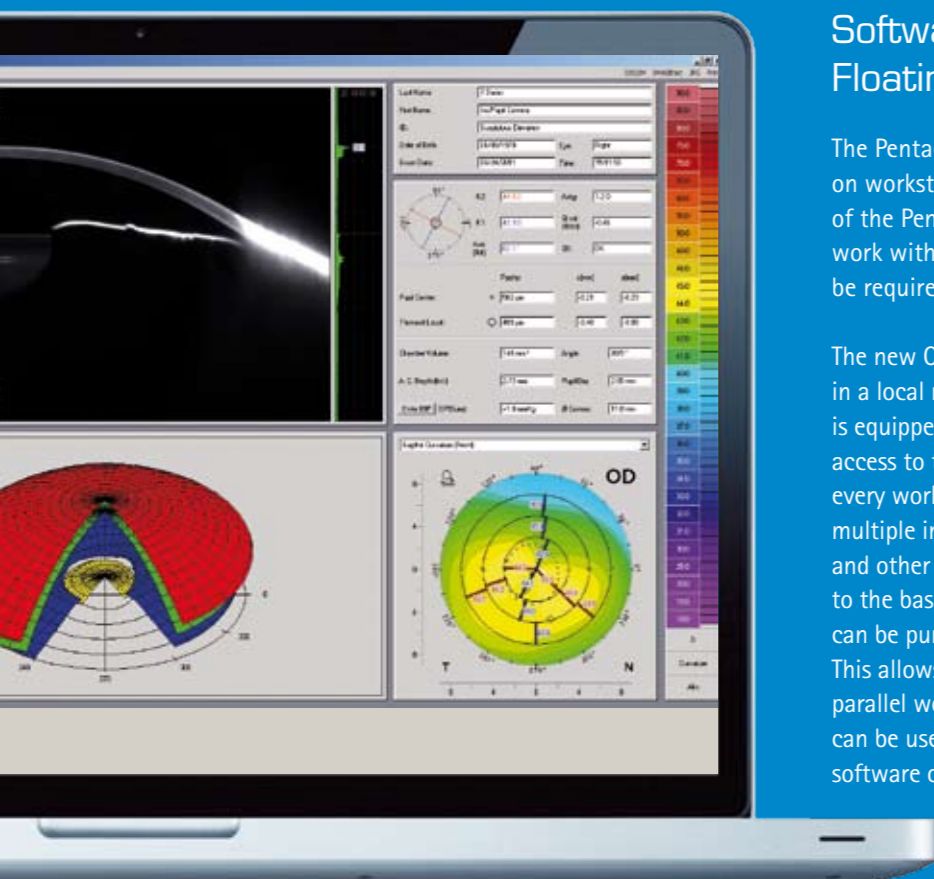

An efficient practice means more time for your patients.

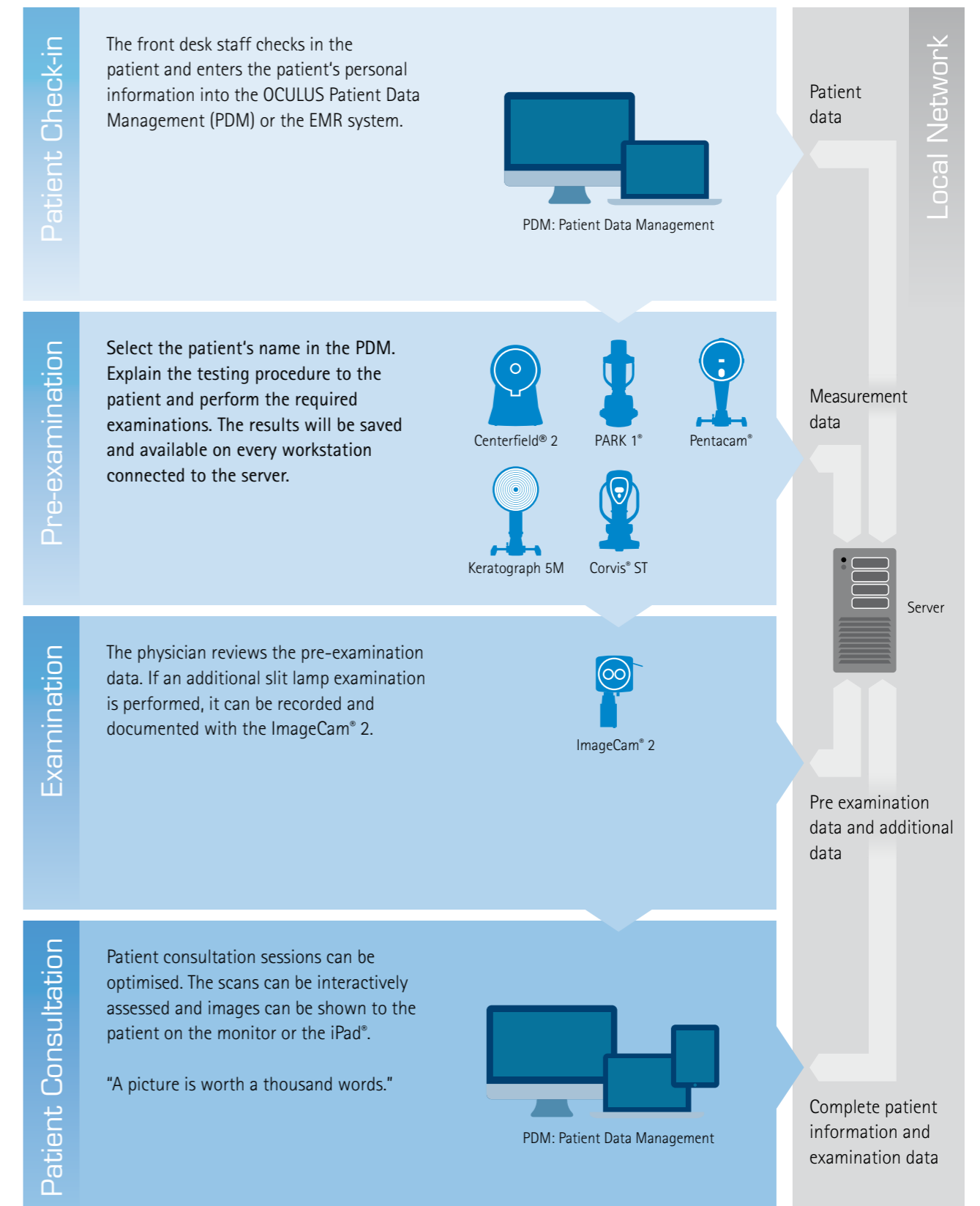



The invisible WIFI access point for the iPad® connection is integrated in the OCULUS lifting tables.

Optional iPad®

Cutting Edge Technology

The **Free** Pentacam® iPad® App



Modern, Easy and Intuitive

OCULUS sets new standards in patient consultation and information. A free Pentacam® Viewer App allows easy transfer of Pentacam® exams to an iPad®.

The Comprehensive Package



Sleek and Ergonomic Design

The iMac stand is attached to the table and the monitor can swivel, providing a shapely, functional solution with no more tangled cables.



Illuminated Up/Down Buttons

Illuminated "Up" and "Down" keys allow easy control of the lift table even when the Pentacam® is operated in a dark or dimmed room.



The Pentacam® Viewer App

Show your patients how you utilise cutting-edge technology in your practice. Download the free Pentacam® Viewer App from the Apple® store to your iPad®.

Clinical Applications

The OCULUS Pentacam® offers many clinical applications for anterior segment analysis.

General Screening

The Indices Display combined with the brilliant Scheimpflug images permit intuitive screening for close angle glaucoma in the anterior segment. Treatment follow-up, documentation and patient education are supported qualitatively as well as quantitatively by various comparison displays.

Refractive Screening and Surgery

Refractive screening and early detection of corneal abnormalities can be performed quickly and intuitively with the Belin/Ambrósio Enhanced Ectasia Display. The OCULUS Pentacam® can help plan for corneal refractive surgery and corneal ring implantation.

Cataract Screening, IOL Power Calculation, Premium IOL Selection

The opacity of the crystalline lens is measured quantitatively and can be shown to patients. The Cataract Pre-Op Display helps in selecting the most suitable premium IOL. Various links to modern IOL power calculators such as Phaco Optics, OKULIX or the BESS II formula are available to assist in challenging cases of post-refractive IOL power calculation and improve the outcome of the toric IOL procedures. The keratometry overlay in the iris image helps with the orientation of toric IOLs.

Cataract Refractive

Planning cataract refractive surgery with phakic IOL implantation becomes a routine process with the OCULUS Pentacam®. A special simulation software including aging prediction is available for iris supported phakic IOLs (pIOLs). It visualises the fit of the pIOL after surgery. The OCULUS Pentacam® provides all necessary information for pre-op planning for ICL implants.

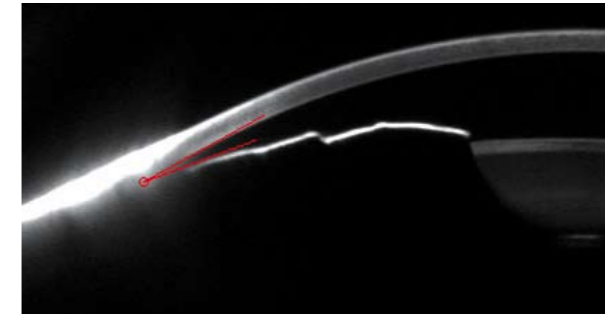

> *Glaucoma Screening*

The Pentacam® provides comprehensive, complete and automatic analysis of the anterior chamber. The instrument displays whether the patient has an increased risk of glaucoma. It shows alterations of the anterior chamber after, for example, an iridectomy or other surgical interventions.

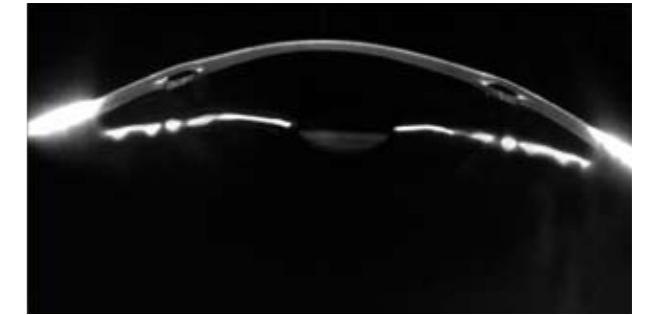

> *Cornea*

The Pentacam® stands out by virtue of its high-resolution images. Surgical success is documented completely from start to finish. Even the smallest irregularities in the healing process are detected early.



> *Cataract*

The Scheimpflug images produced by the Pentacam® offer a clear representation of lens opacity. The 3D cataract analysis combined with PNS (Pentacam® Nucleus Staging) is a unique feature. The centre of the cornea and its anterior and posterior surfaces are measured precisely for optimal calculation of corneal refractive power. This translates into better IOL power calculation. The Pentacam® supports the selection of the optimal premium IOL for the respective patient. All measurements are performed with the same high precision device and during the same eye examination.



> *Cataract Refractive*

The Pentacam® data helps the doctor decide whether the patient is a suitable candidate for a certain procedure, such as premium IOL implantation. The Pentacam® images can be used as a patient education tool to explain the condition and the surgical procedure. The Pentacam® simulates the position of iris fixated phakic IOLs in 3D. Moreover, the Pentacam® simulates the future position of the pIOL.

Brilliant Images



Enhance your diagnosis

The real images of the anterior segment obtained with the Pentacam® can enhance your diagnosis. These images provide valuable insight into the condition of the cornea, iris, anterior chamber and the crystalline lens or intraocular lens. It is easy to detect narrow chamber angles or early cataracts by looking at these high resolution images. The best part is that these images are documented and can be shown to the patient to describe the medical findings and discuss treatment options.

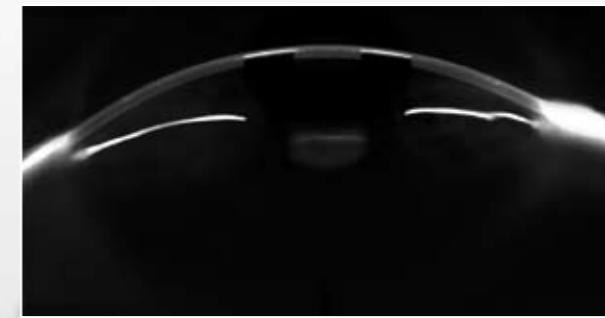

> Corneal inlay for presbyopia correction

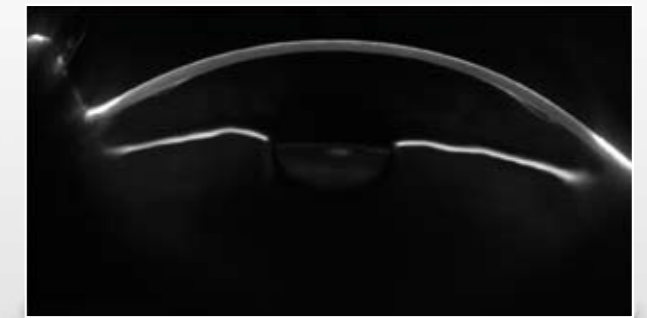

> Endothelial detachment after Descemet Membrane Endothelium Keratoplasty (DMEK)



> High keratoconus causing an extreme central thinning

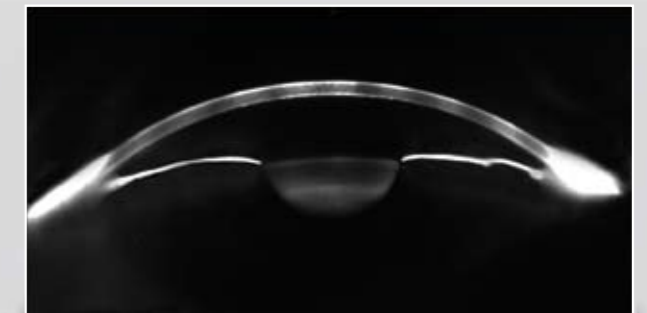

> Cornea with Fuchs' endothelial dystrophy



> Pterygium – beginning growth of the conjunctiva



> Descemet stripping and automated endothelium keratoplasty (DSAEK) after Fuchs' endothelial dystrophy



> Penetrating keratoplasty – corneal transplant after Fuchs' endothelial dystrophy



> Pellucid marginal degeneration – an inferior band of corneal thinning



Basic Software

Discover the Possibilities

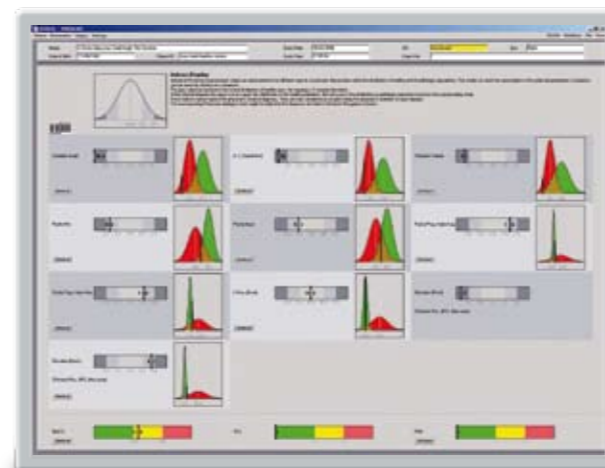

Indices Display ✳

Applications:

- Quick screening of new patients
- Detection of abnormalities
- Intuitive guide through the Pentacam®/Pentacam® HR software

Details:

Important parameters of the anterior eye segment that are displayed with the Pentacam®/Pentacam® HR software are analysed and validated in published papers and articles. Their normal (green) and pathological (red) distribution is displayed in diagrams. This presentation provides an intuitive, quick but comprehensive overview. The literature source used is also mentioned, permitting detailed

Based on individual results the software recommends further displays to review additional details.

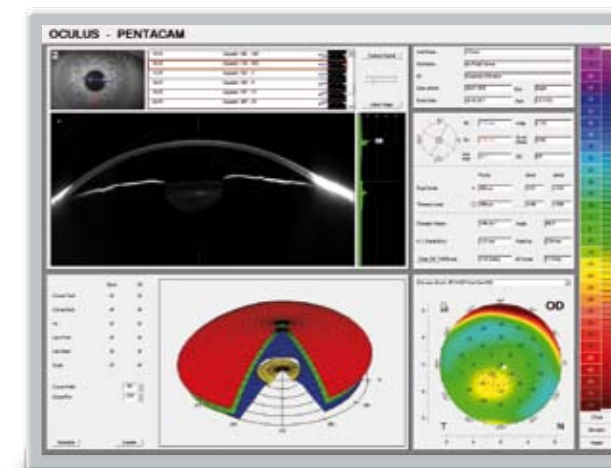

General Overview

Applications:

- Comprehensive clinical overview
- Patient information

Details:

The Overview Display provides important clinical information on the anterior eye segment.

The Scheimpflug image provides physician and patient an intuitive representation of opacities of the cornea and lens (cataract) or of the position of an IOL. The corneal keratometry, pachymetry and asphericity are displayed. The anterior chamber is described in terms of anterior chamber depth, volume and angle. When combined with tonometry readings the IOP can be corrected with reference to corneal thickness to permit an assessment of possible glaucoma risks. It also allows the display of all colour maps.

✳ These functions are unique and are only available with the OCULUS Pentacam®

Basic Software

Discover the Possibilities

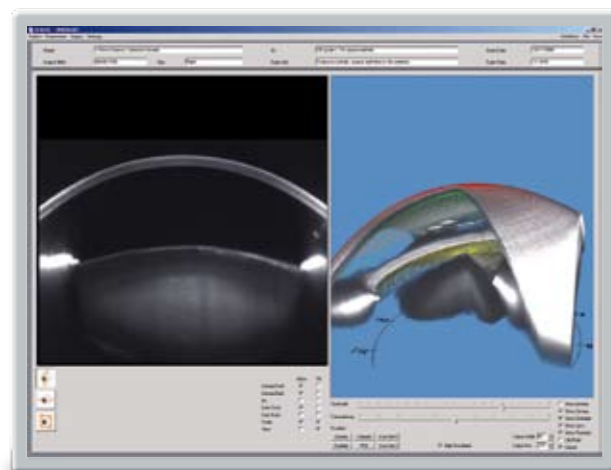

Anterior Segment Tomography ✳

Applications:

- Fast overview of gathered data
- Changes which become visible in the Scheimpflug image are represented amazingly well in a 3D model.

Details:

The rotatable and movable 3D model of the anterior eye segment proves an enormous help in patient education. The patient can see his or her eye from all sides. Irregularities and scars can be explained easily.

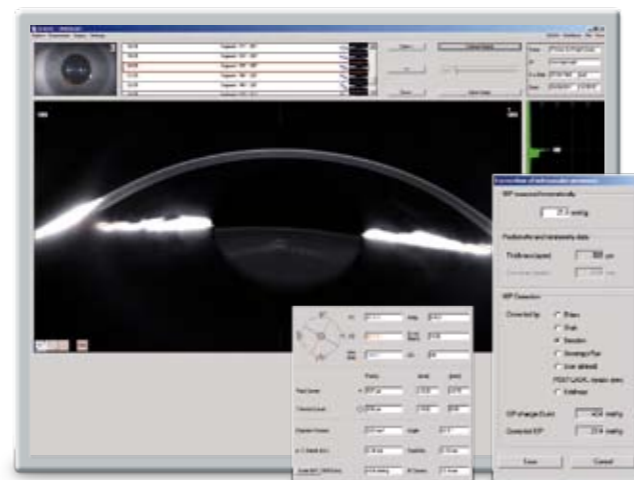

3D Anterior Chamber Analysis

Applications:

- Glaucoma screening
- Pre- to post-operative comparison of changes in anterior chamber, e.g. after iridectomy
- Tomographic representation, virtual model of anterior segment
- Automatic calculation of
 - ✳ Anterior chamber angles (ACA)
 - Anterior chamber volume (ACV)
 - Internal or external anterior chamber depth (ACD)

Details:

The high resolution images and the 3D Anterior Chamber Analysis are used to assess the anterior segment for abnormalities. This information can be easily shared with the patient to explain the condition and discuss treatment options.

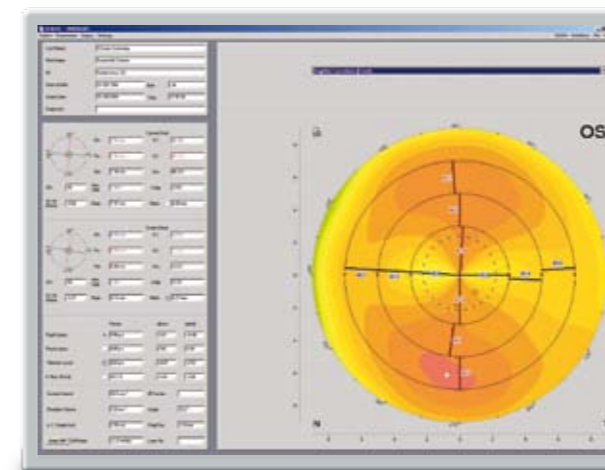

Topography Maps of the Anterior and Posterior Corneal Surface

Applications:

- Keratoconus detection
- Pre-surgical planning of corneal refractive surgery
- Follow-up after corneal surgery
- Calculation of IOL refractive power
- Planning of astigmatism of limbal relaxing incisions (LRI)
- Follow-up after refractive surgery
- Pre-post LASIK, PRK, PKP, LKP, DSEK

Details:

The rotating measurement principle guarantees high resolution of the measuring points in the central cornea. Topographic analysis of the anterior and posterior corneal surfaces is based on measured real height data. These provide the basis for:

- Sagittal (axial), tangential (local) curvature maps, refractive power maps of the anterior and posterior corneal surface
- Elevation maps of the anterior and posterior corneal surface
- Four colour coded maps display for refractive assessment
- Topometric display for detailed corneal shape assessment including true net power
- Topography based keratoconus detection and classification
- Comparison and differential displays

✳ These functions are unique and are only available with the OCULUS Pentacam®

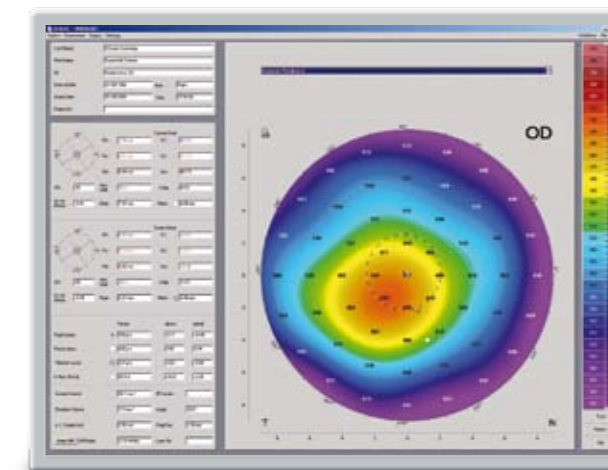

Pachymetry Maps

Applications:

- Pre-surgical planning of corneal refractive surgery
- Absolute and relative presentation
- Glaucoma screening
- Relative pachymetry map for early keratoconus detection
- IOP correction taking into account measured corneal thickness based on various correction formulas (for e.g. Ehler, Shah, Dresden etc.)

Details:

An overview representation in colour shows the corneal thickness from limbus to limbus. The measured values can be displayed in a pre-determined grid or represented manually at any point via mouse click.

Automatic representation of:

- Corneal thickness in the centre of the pupil
- Corneal thickness in the apex
- The thinnest point of the cornea

Basic Software

Discover the Possibilities

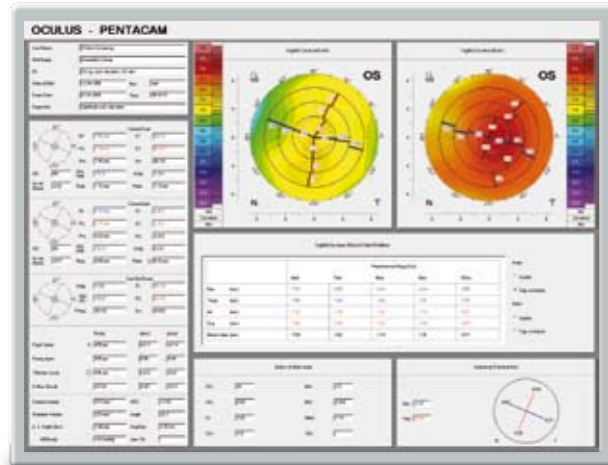

Topometric

Applications:

- Corneal shape assessment
- Detection and classification of corneal abnormalities

Details:

The early detection and follow-up of corneal shape abnormalities such as keratoconus and others is a vital part of the eye specialist's everyday practice. The software performs an objective classification of anterior corneal shape abnormalities based on various indices. The anterior and posterior corneal curvature are displayed in order to:

- Detect differences in terms of the axis of the astigmatism
- Early detection of posterior shape abnormalities.



Iris Camera

Applications:

- Overview image of the iris to recognise landmarks
- Automatic determination of the corneal diameter (HWTW)
- Determination of pupil location and shape

Details:

The Pentacam® and the Pentacam® HR are equipped with an improved iris camera optic. The corneal diameter (HWTW) is calculated automatically from the iris photo. It can be used for the selection and calculation of IOLs and pIOLs as well as for contact lenses.

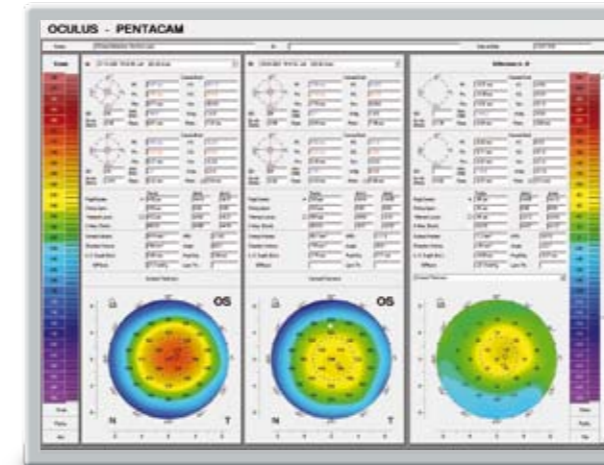

Comparison and Differential Analysis of 2 Exams

Application:

- Objective changes and progression analysis

Details:

Two exams can be loaded and analysed. The difference between the two loaded exams is shown. The colour maps and parameters can be assessed and compared.

The display consists of three parts:

- Numerical, for pure data comparison
- Combined, with maps and values
- Colour maps only



Comparison and Superimposition of Scheimpflug Images ✱

Applications:

- Comparison of the Scheimpflug images of two different exams
- Visualisation of changes after surgical intervention
- Patient education

Details:

The superimposition of the Scheimpflug images includes a blending function to qualitatively visualise and analyse changes in the anterior chamber.

Examples:

- Cornea, before and after LASIK
- Anterior chamber condition before and after iridotomy
- Progression of lens opacifications (cataract)

Additional Software

Refractive Software Package

This Package Contains:

- ✳ Overview Display for refractive surgeons
- ✳ Corneal, optical densitometry analysis in different layers and zones qualitatively and quantitatively
- ✳ Corneal thickness progression analysis for early keratoconus detection
- Fourier Analysis Display
- Freely selectable Four Maps Display
- Extended comparative and differential analysis of up to four examinations
- Side-by-side comparison of two examinations
- Side-by-side comparison of topometric and pachymetric data
- Freely selectable reference bodies for elevation maps

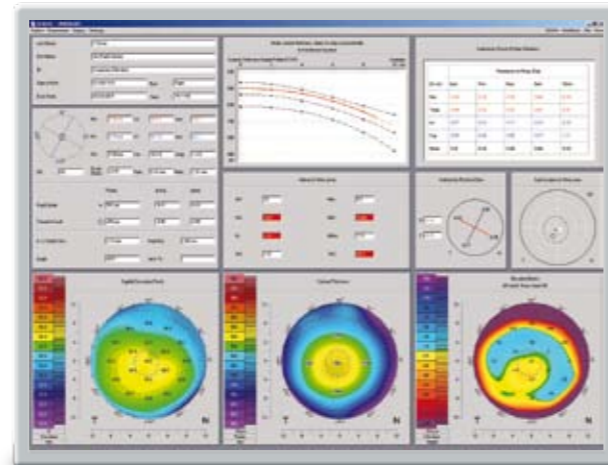

Overview Display for Refractive Surgeons

Applications:

- Comprehensive corneal shape assessment
- General printout

Details:

The keratometry and corneal pachymetry are displayed as colour maps or presented in terms of important parameters like the thinnest location. The corneal thickness progression combined with the topographic evaluation of the anterior corneal shape gives a first hint of a possible irregular cornea. The sagittal (axial) curvature map, together with corneal asphericity data, provides a detailed analysis of the corneal shape. The posterior elevation and pachymetry maps complete the evaluation of early signs of keratoconus or post LASIK ectasia.

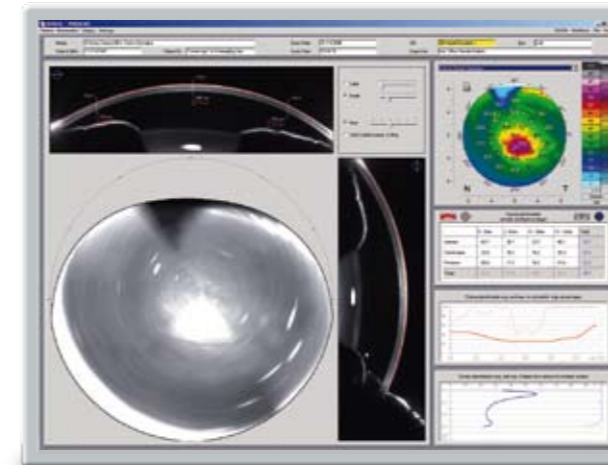

Corneal Optical Densitometry ✳

Applications:

- Objective analysis of corneal optical density. For example before and after CXL, PRK, LASIK, DSEK etc.
- Detection of corneal diseases like Fuchs dystrophy or corneal scars

Details:

In the past, objective evaluation of the corneal optical densitometry was not possible. Now the new Pentacam® / Pentacam® HR software allows customised and standardised evaluation of corneal densitometry.

The corneal optical densitometry

- is displayed as a colour coded map over its full depth and area.
- can be assessed individually in different layers and zones. The respective layer depth and zone size are displayed in the two Scheimpflug images as well as in a coloured or grey scaled map.
- is displayed in fixed layers and zones for study purposes in the table chart.

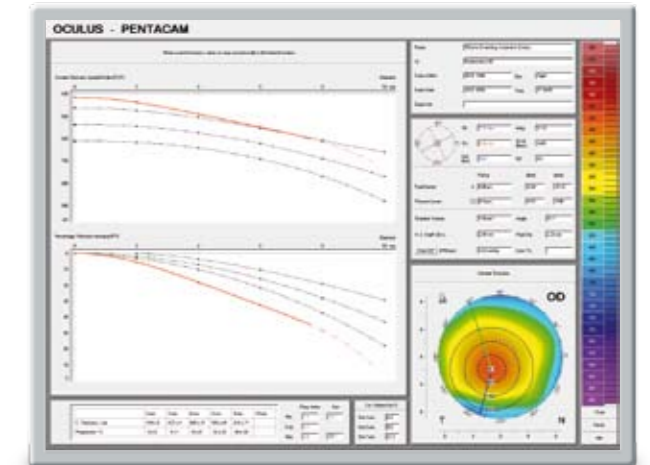

Corneal Thickness Progression ✳

Applications:

- Early detection of corneal abnormalities like keratoconus or Fuchs dystrophy

Details:

Corneal thickness progression is analysed on concentric rings around the thinnest point towards the periphery. It is displayed in two diagrams and numeric parameters. Corneal thickness progression is different in normal corneas than it is in a cornea with keratoconus or Fuchs dystrophy. Often corneal thickness progression gives the first hint of an abnormality.

✳ These functions are unique and are only available with the OCULUS Pentacam®

Additional Software

Refractive Software Package

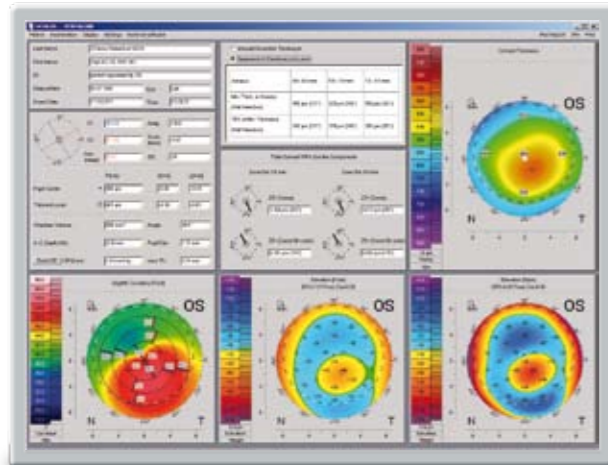

Corneal Rings

Applications:

- Pre-op planning
- Minimum corneal thickness is shown according to the operation method
 - for manual dissection technique
 - for Femto laser treatments
- Orientation of the corneal rings with regard to keratometry or coma axis
- Qualitative and quantitative assessment of corneal properties

Details:

The Pentacam® can measure very irregular corneas with advanced keratoconus. This assists the surgeon pre-operative planning for corneal ring implantation. Essential data include the minimum corneal thickness and its axis, but how these are best presented will depend on the operation technique. In the Pentacam® they are shown for manual dissection technique as well as for Femto laser controlled treatments. The following data are shown to assist in the orientation of the corneal ring:

- Keratometry
- 3rd and 5th order coma aberration.

These colour maps provide a comprehensive overview of corneal conditions.

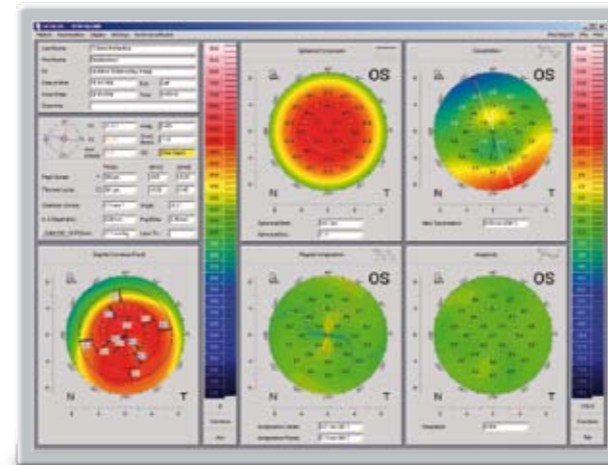

Fourier Analysis

Applications:

- Assessment of differences in the astigmatism axis
- Assessment of achievable optical outcome

Details:

The shape of the cornea is broken down into its spherical, astigmatic and its remaining irregular components. The regular astigmatic component shows the difference in axis orientation between the centre and the periphery. This information is essential when fitting contact lenses for highly irregular corneas.

The remaining irregularities give an indication of the retinal image quality which can be achieved with glasses or contact lenses.

Additional Software

Cataract Software Package

Cataract Software Package

- Cataract Pre-Op Display, developed in collaboration with Prof. Naoyuki Maeda, MD, for the pre-op assessment of corneal optical quality to select premium IOLs
- ✳️ PNS and 3D Cataract Analysis
- Corneal Wavefront and Zernike Analysis of the total cornea
- True measurements in Scheimpflug images
- Power Distribution Display/Total Corneal Refractive Power for improved IOL power calculation
- Orientation of toric IOLs
- True Net Corneal Power
- Extended comparative and differential analysis of up to four examinations
- Side-by-side comparison of two examinations
- Side-by-side comparison of topometric and pachymetric data
- Four maps, anterior chamber
- Four maps, topometric
- Anterior Chamber Depth Map
- Anterior chamber angle in 360°, automatic

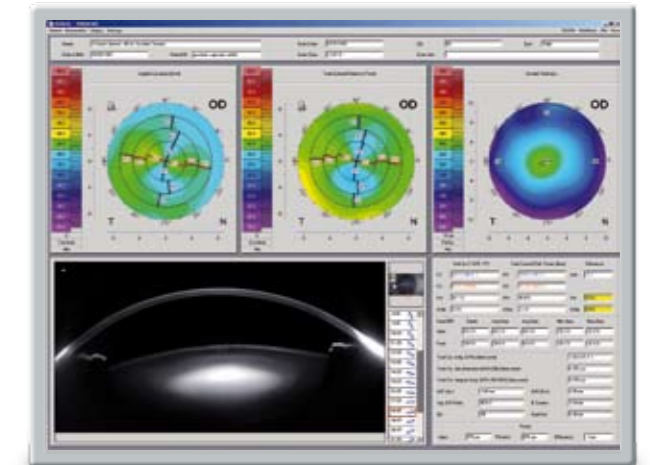

Evaluation of Corneal Optical Quality for Premium IOLs

Applications:

- 4 steps in assessing corneal optical properties:
- Evaluation of corneal irregular astigmatism
 - Detection of abnormal corneal shape
 - Evaluation of corneal spherical aberration
 - Evaluation of corneal cylinder

Details:

Thanks to the availability of new IOL designs such as toric, multifocal or aspheric, surgeons are today better able to improve the visual outcome of their patients. To support surgeons in the selection of the best premium IOL a new display called "Cataract Pre-Op" was developed in co-operation with Prof. Naoyuki Maeda, University Medical School, Osaka, Japan.

Additional Software

Cataract Software Package



PNS and 3D Cataract Analysis ✖

Applications:

- ✖ Objective quantification of lens opacities (densitometry) in 2D and 3D
- ✖ Graduation of lens opacities (PNS)
 - Visualisation of lens opacities
 - Visualisation of posterior capsular opacities (PCO)
 - Representation of Bowman's membrane

Details:

Opacities of the natural lens are made visible by blue light illumination. The excellent quality of the Scheimpflug images allows automatic and objective quantification of lens opacities.

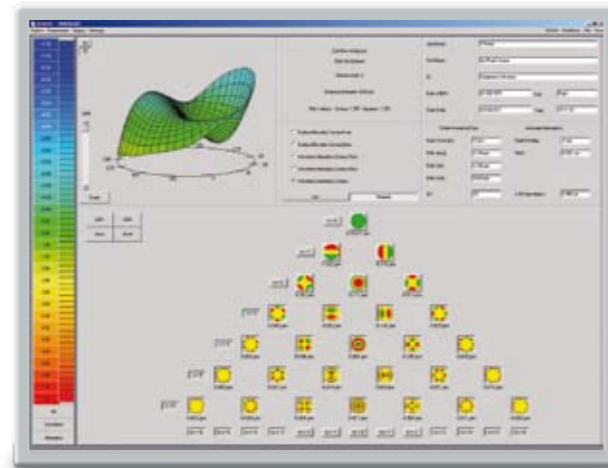

Corneal Wavefront Analysis

Applications:

- Selection of aspheric IOLs for correction of corneal spherical aberrations (Z4.0)
- Fitting of corneal rings according to the axis of coma
- Determination of low and high order aberrations

Details:

Zernike Analysis as performed by the Pentacam® consists of two parts:

- Calculation of the corneal wavefront for the entire cornea (anterior and posterior surface) is performed via ray tracing and is thus independent of the shape of the cornea (e.g. post LASIK, PRK, LKP, PKP etc).
- Surface based Zernike Analysis is performed with respect to, e.g., an ideal corneal ellipse (ecc=0.751). This can be shown separately for the anterior and posterior surface of the cornea.

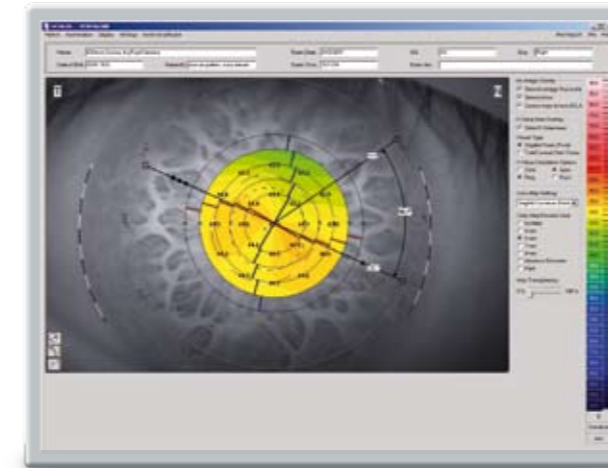

Keratometry Overlay on the Iris Image

Applications:

- Assessing pupil size and shape with regard to corneal power
- Evaluation of differences between anterior corneal power and total corneal refractive power
- Defining a pointer to an iris mark to compensate for cyclo-rotation
- Evaluation of virtual pupil size as compared to true pupil size

Details:

The keratometry of the anterior sagittal power as well as the total corneal refractive power are projected onto the iris image. This allows, e.g., pre-op evaluation for toric IOL implantation to see possible differences in the axis of the astigmatism. The keratometry is calculated with reference to the corneal apex or to the pupil centre. A marker can be defined for prominent landmarks to compensate for cyclo-rotation. Finally the colour maps are projected onto the pupil area or apex for comprehensive pre-op assessment and planning.

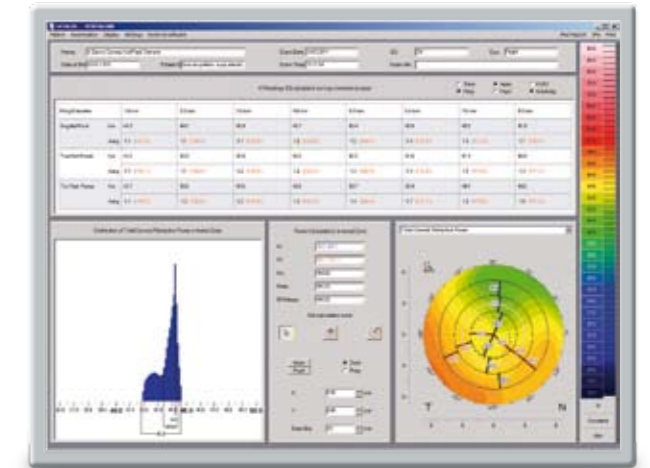

Corneal Power Distribution

Applications:

- Comparing anterior sagittal power with total corneal refractive power
- Detecting differences in axis orientation of corneal astigmatism between different zones taking pupil diameter under scotopic and mesopic conditions into account
- Calculation of corneal power in different zones or for rings of definable diameter around the corneal apex or pupil centre
- Assessment of corneal power distribution

Details:

The Corneal Power Distribution Display allows a detailed assessment of corneal power in different zones and rings from 1mm up to 8mm in the table chart. Data is presented in reference to the pupil centre or the corneal apex. This display makes it easy to determine the amount and axis of posterior corneal astigmatism and compare the result with anterior surface conditions. Corneal power can be individually calculated in every zone/ring around the corneal apex.

✖ These functions are unique and are only available with the OCULUS Pentacam®

Additional Software Modules

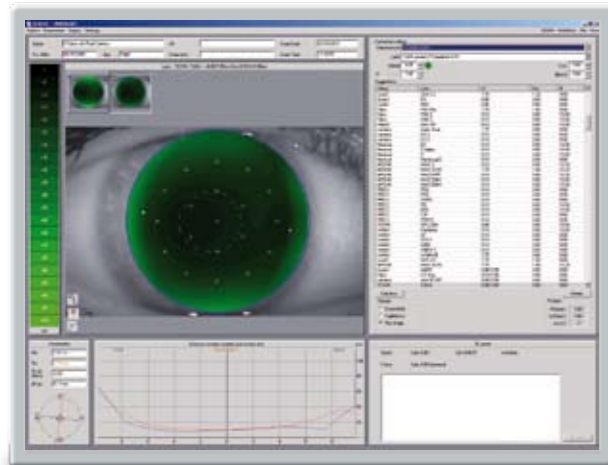

Contact Lens Fitting

Applications:

- Automatic display of all measurement data required for contact lens fitting
- Automatic suggestion of contact lenses
- Realistic fluorescein image simulation
- Integrated and expandable contact lens database with over 560,000 lens geometries

Details:

Dynamic fluorescein image simulation makes it possible to view the fit of contact lenses in advance. The integrated expandable contact lens database contains over 560,000 lens geometries. The user can draw up his own rating list and add further contact lenses to the database as required. The inclination and position of the contact lens can be customised manually.

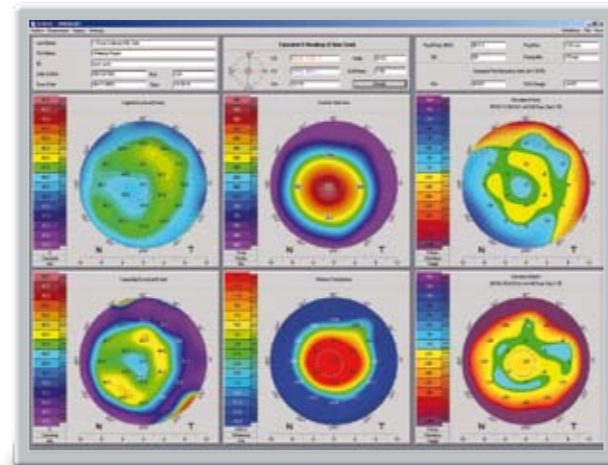

Holladay Report and Holladay EKR Report ✖

Applications:

- Comprehensive clinical comparative representations ✖ EKR (Equivalent Keratometer Readings) for optimised IOL power calculations for post-refractive patient eyes in cases where pre-op data are not available

Details:

The Holladay Report was developed in collaboration with Jack T. Holladay, MD, USA. It supplies data for IOL power calculation for patients who have undergone refractive corneal surgery such as LASIK or RK. This is especially useful in cases where pre-op data are not available. The Holladay Report calculates the true relationship between the posterior and anterior corneal surfaces. The overall refractive power of the cornea is calculated and described in various zones using EKRs. These can be used in IOL formulas, e.g. the Holladay 2 Formula.

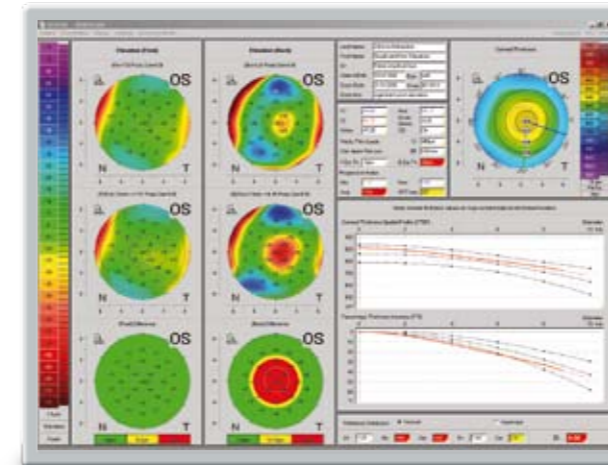

Belin/Ambrósio Enhanced Ectasia Display ✖

Applications:

- Minimises "false positives" and "false negatives"
- Detection of keratoconus in very early stages
- Includes a database for myopic and hyperopic eyes

Details:

The Belin/Ambrósio Enhanced Ectasia display is the first screening tool which combines elevation data of the anterior and posterior corneal surface with corneal thickness progression analysis. It was developed in collaboration with Prof. Michael W. Belin, MD, USA and Renato Ambrósio Jr., MD, Brazil. Originally designed for myopic eyes the Belin/Ambrósio is now also available for hyperopic eyes. In addition to its overall more precise keratoconus detection this screening facilitates early detection in particular. Corneal thickness progression analyses are calculated using concentric rings, starting at the thinnest point and extending to the periphery. Evaluation of deviations from the standard elevation map and the enhanced elevation map is facilitated by displaying the results in green, yellow and red. Several indices are calculated individually and then combined into one global index and displayed colour coded.

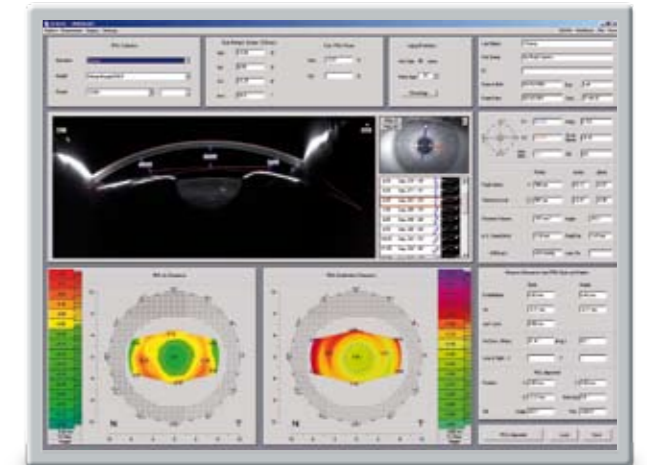

3D pIOL Simulation Software and Aging Prediction ✖

Applications:

- Pre-surgical planning of an iris-fixated pIOL
- Simulation of the post-operative position of the iris-fixated pIOL
- Simulation of age-related lens growth and the position of the iris-fixated pIOL resulting from this
- Patient selection

Details:

The examiner enters the subjective refraction result. The software calculates the refractive power required for the selected pIOL type using the "van der Heyde formula". The examiner accordingly selects a pIOL from the current database. The position of the pIOL in the anterior chamber is automatically calculated in 3D and represented in the Scheimpflug images. The minimal distances between

- the pIOL and the crystalline lens
- the pIOL and the endothelium

are calculated automatically in 3D and displayed numerically and with a colour map. The results can be shown to the patient. This software module is available for the Pentacam® HR only.

✖ These functions are unique and are only available with the OCULUS Pentacam®

Technical Data

All Pentacam® Models

Feature	Pentacam®	Pentacam® HR
Camera	digital CCD camera	digital CCD camera
Light source	blue LEDs (475 nm UV-free)	blue LEDs (475 nm UV-free)
Processor	DSP with 400 mil. operations/s	DSP with 400 mil. operations/s
Speed	50 images in 2 seconds ¹⁾	100 images in 2 seconds ²⁾
Dimensions (HxWxD)	535x280x360 mm	535x280x360 mm
Weight	9 kg	9 kg
PC minimum requirements	Pentium® IV, 1.5 GHz, Windows® XP, 2 GB RAM, VGA graphic card 1024 x 768 true color, SB interface	Pentium® IV, 1.5 GHz, Windows® XP, 2 GB RAM, VGA graphic card 1024 x 768 true color, SB interface

Measurement Range	Pentacam®	Pentacam® HR
Precision	± 0.2 D	± 0.1 D
Reproducibility	± 0.2 D	± 0.1 D
Operating distance	80 mm	80 mm

¹⁾ Scheimpflug image of the entire anterior segment

²⁾ Cornea fine scan

CE in accordance with Medical Products Directive 93/42/EEC

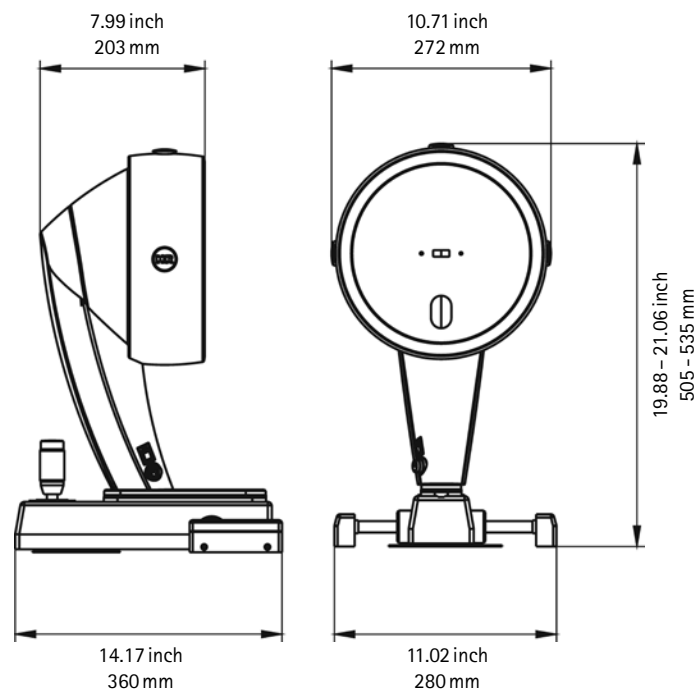

WWW.OCULUS.DE

OCULUS Optikgeräte GmbH
 Postfach • 35549 Wetzlar • GERMANY
 Tel. +49-641-2005-0 • Fax +49-641-2005-295
 Email: export@oculus.de • www.oculus.de

- OCULUS USA, sales@oculususa.com
- OCULUS Asia, info@oculus.hk
- OCULUS Czechia, oculus@oculus.cz
- OCULUS Iberia, info@oculus.es
- OCULUS Poland, biuro@oculus.pl



OCULUS is certified by TÜV according to
 DIN EN ISO 13485/DIN EN ISO 9001

